

Communicative damper actuator for adjusting dampers in technical building installations

- Air damper size up to approx. 2 m<sup>2</sup>
- Nominal torque 10 Nm
- Nominal voltage AC/DC 24 V
- Control Modulating DC (0)2...10 V Variable
- Position feedback DC 2...10 V Variable
- Conversion of sensor signals
- Communication via Belimo MP-Bus

**Technical data**

<b>Electrical data</b>	Nominal voltage	AC/DC 24 V
	Nominal voltage frequency	50/60 Hz
	Nominal voltage range	AC 19.2...28.8 V / DC 21.6...28.8 V
	Power consumption in operation	4 W
	Power consumption in rest position	1.5 W
	Power consumption for wire sizing	7 VA
	Connection supply / control	Cable 1 m, 4 x 0.75 mm <sup>2</sup>
	Parallel operation	Yes (note the performance data)
<b>Functional data</b>	Torque motor	Min. 10 Nm
	Torque variable	25%, 50%, 75% reduced
	Positioning signal Y	DC 0...10 V
	Positioning signal Y note	Input impedance 100 kΩ
	Control signal Y variable	Open-close 3-point (AC only) Modulating (DC 0...32 V)
	Operating range Y	DC 2...10 V
	Operating range Y variable	Start point DC 0.5...30 V End point DC 2.5...32 V
	Position feedback U	DC 2...10 V
	Position feedback U note	Max. 0.5 mA
	Position feedback U variable	Start point DC 0.5...8 V End point DC 2.5...10 V
	Position accuracy	±5%
	Direction of motion motor	Selectable with switch 0 / 1
	Direction of motion note	Y = 0 V: At switch position 0 (ccw rotation) / 1 (cw rotation)
	Direction of motion variable	Electronically reversible
	Manual override	Gear disengagement with push-button, can be locked
	Angle of rotation	Max. 95°
	Angle of rotation note	can be limited on both sides with adjustable mechanical end stops
	Running time motor	35 s / 90°
	Motor running time variable	20...75 s
	Adaption setting range	manual
	Adaption setting range variable	No action Adaption when switched on Adaption after pushing the gear disengagement button
	Override control	MAX (maximum position) = 100% MIN (minimum position) = 0% ZS (intermediate position, AC only) = 50%
	Override control variable	MAX = (MIN + 32%)...100% MIN = 0%...(MAX - 32%) ZS = MIN...MAX
Sound power level motor	45 dB(A)	
Spindle driver	Universal spindle clamp 8...26.7 mm	
Position indication	Mechanically, pluggable	
<b>Safety</b>	Protection class IEC/EN	III Safety extra-low voltage

## Technical data

<b>Safety</b>	Protection class UL	UL Class 2 Supply
	Degree of protection IEC/EN	IP54
	Degree of protection NEMA/UL	NEMA 2, UL Enclosure Type 2
	EMC	CE according to 2004/108/EC
	Certification IEC/EN	IEC/EN 60730-1 and IEC/EN 60730-2-14
	Certification UL	cULus according to UL 60730-1A, UL 60730-2-14 and CAN/CSA E60730-1:02
	Mode of operation	Type 1
	Rated impulse voltage supply / control	0.8 kV
	Control pollution degree	3
	Ambient temperature	-30...50 °C
	Non-operating temperature	-40...80 °C
	Ambient humidity	95% r.h., non-condensing
	Maintenance	Maintenance-free
	<b>Weight</b>	Weight

## Safety notes



- The device must not be used outside the specified field of application, especially not in aircraft or in any other airborne means of transport.
- Outdoor application: only possible in case that no (sea)water, snow, ice, insolation or aggressive gases interfere directly with the actuator and that is ensured that the ambient conditions remain at any time within the thresholds according to the data sheet.
- Only authorised specialists may carry out installation. All applicable legal or institutional installation regulations must be complied during installation.
- The device may only be opened at the manufacturer's site. It does not contain any parts that can be replaced or repaired by the user.
- Cables must not be removed from the device.
- To calculate the torque required, the specifications supplied by the damper manufacturers concerning the cross-section, the design, the installation site and the ventilation conditions must be observed.
- The device contains electrical and electronic components and must not be disposed of as household refuse. All locally valid regulations and requirements must be observed.

## Product features

<b>Mode of operation</b>	Conventional operation: The actuator is connected with a standard modulating signal of DC 0...10V and drives to the position defined by the positioning signal. The measuring voltage U serves for the electrical display of the actuator position 0...100% and as slave control signal for other actuators. Operation on the MP-Bus: The actuator receives its digital positioning signal from the higher level controller via the MP-Bus and drives to the position defined. Connection U serves as communication interface and does not supply an analogue measuring voltage.
<b>Converter for sensors</b>	Connection option for a sensor (passive or active sensor or switching contact). The MP actuator serves as an analogue/digital converter for the transmission of the sensor signal via MP-Bus to the higher level system.
<b>Parameterisable actuators</b>	The factory settings cover the most common applications. Single parameters can be modified with the Belimo Service Tools MFT-P or ZTH EU.
<b>Simple direct mounting</b>	Simple direct mounting on the damper spindle with an universal spindle clamp, supplied with an anti-rotation device to prevent the actuator from rotating.
<b>Manual override</b>	Manual override with push-button possible (the gear is disengaged for as long as the button is pressed or remains locked).
<b>High functional reliability</b>	The actuator is overload protected, requires no limit switches in intermediate positions and automatically stops when the end stop is reached (at rest).
<b>Adjustable angle of rotation</b>	Adjustable angle of rotation with mechanical end stops.

## Product features

**Home position** The first time the supply voltage is switched on, i.e. at the time of commissioning, the actuator carries out a synchronisation. The synchronisation is in the home position (0%).  
The actuator then moves into the position defined by the positioning signal.

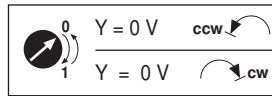

**Adaption and synchronisation** An adaption can be triggered manually by pressing the “Adaption” button or with the PC-Tool. Both mechanical end stops are detected during the adaption (entire setting range).  
Automatic synchronisation after pressing the gearbox disengagement button is configured. The synchronisation is in the home position (0%).  
The actuator then moves into the position defined by the positioning signal.  
A range of settings can be adapted using the PC-Tool (see MFT-P documentation)

## Accessories

	Description	Type
<b>Gateways</b>	Gateway MP to Modbus RTU, AC/DC 24 V	UK24MOD
	Gateway MP for BACnet MS/TP, AC/DC 24 V	UK24BAC
	Gateway MP to LonWorks, AC/DC 24 V, LonMark certified	UK24LON
	Gateway MP to KNX, AC/DC 24 V, EIBA certified	UK24EIB
<b>Electrical accessories</b>	<b>Description</b>	<b>Type</b>
	Auxiliary switch, add-on, 1 x SPDT	S1A
	Auxiliary switch, add-on, 2 x SPDT	S2A
	Auxiliary switch, add-on, 2 x SPDT, grey	S2A GR
	Feedback potentiometer 140 Ohm, add-on	P140A
	Feedback potentiometer 140 Ohm, add-on, grey	P140A GR
	Feedback potentiometer 200 Ohm, add-on	P200A
	Feedback potentiometer 500 Ohm, add-on	P500A
	Feedback potentiometer 500 Ohm, add-on, grey	P500A GR
	Feedback potentiometer 1 kOhm, add-on	P1000A
	Feedback potentiometer 2.8 kOhm, add-on	P2800A
	Feedback potentiometer 2.8 kOhm, add-on, grey	P2800A GR
	Feedback potentiometer 1 kOhm, add-on, grey	P1000A GR
	Feedback potentiometer 5 kOhm, add-on	P5000A
	Feedback potentiometer 5 kOhm, add-on, grey	P5000A GR
	Feedback potentiometer 10 kOhm, add-on	P10000A
	Feedback potentiometer 10 kOhm, add-on, grey	P10000A GR
	Signal converter voltage/current, supply AC/DC 24V	Z-UIC
	Digital position indicator for front-panel mounting, 0...99%, front mass 72 x 72 mm	ZAD24
	Range controller for wall mounting, adjustable electron. Min./max. angle of rotation limitation	SBG24
	Positioner for wall mounting, range 0...100%	SGA24
	Positioner in a conduit box, range 0...100%	SGE24
Positioner for front-panel mounting, range 0...100%	SGF24	
Positioner for wall mounting, range 0...100%	CRP24-B1	
Connecting cable 5 m, A+B: RJ12 6/6, To ZTH/ZIP-USB-MP	ZK1-GEN	
Connection cable 5 m, A: RJ11 6/4, B: Free wire end, To ZTH/ZIP-USB-MP	ZK2-GEN	
MP-Bus power supply for MP actuators, AC 230/24V for local power supply	ZN230-24MP	
Connecting board MP bus suitable for wiring boxes EXT-WR-FP...-MP	ZFP2-MP	
<b>Mechanical accessories</b>	<b>Description</b>	<b>Type</b>
	Actuator arm, for one-sided spindle clamp K-ENSA	AH-25
	Shaft extension 250 mm, for damper spindles Ø 8...25 mm	AV8-25

Accessories

Description	Type
Angled ball joint with M8, suitable for damper crank arms KH8	KG8
Straight ball joint with M8, suitable for damper crank arms KH8	KG10A
Damper crank arm, for damper spindles	KH8
Spindle clamp, one side for NM..A	K-ENMA
Spindle clamp, one side for NM..A, SM..A	K-ENSA
Spindle clamp, reversible for NM..A and LMQ..	K-NA
Angle of rotation limiter, for K-NA	20334-00001
Form fit insert 8x8 mm, for NM..A	ZF8-NMA
Form fit insert 10x10 mm, for NM..A / SM..A	ZF10-NSA
Form fit insert 12x12 mm, for NM..A / SM..A	ZF12-NSA
Form fit insert 15x15 mm	ZF15-NSA
Form fit insert 16x16 mm, for NM..A / SM..A	ZF16-NSA
Mounting kit for linkage operation, NM..A for flat installation	ZG-NMA
Universal mounting bracket 180 mm	Z-ARS180
Base plate extension from NM..A to NM..	Z-NMA
Position indication for LM..A, NM..A, SM..A, GM..A	Z-PI

Service Tools	Description	Type
	Service Tool, for MF/MP/Modbus/LonWorks actuators and VAV-Controller	ZTH EU
Belimo PC-Tool, software for adjustments and diagnostics	MFT-P	
Adapter to Service-Tool ZTH	MFT-C	

Electrical installation



Notes

- Connection via safety isolating transformer.
- Parallel connection of other actuators possible. Observe the performance data.

Wiring diagrams

AC/DC 24 V, modulating

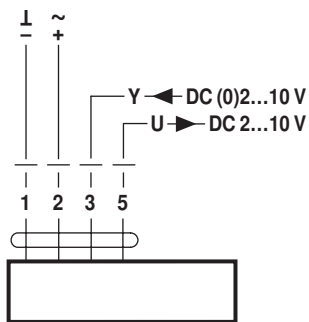

Cable colours:

- 1 = black
- 2 = red
- 3 = white
- 5 = orange

Operation on the MP-Bus

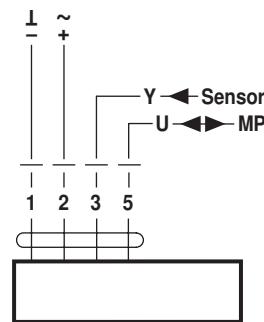

Cable colours:

- 1 = black
- 2 = red
- 3 = white
- 5 = orange

Functions

Functions when operated on MP-Bus

Connection on the MP-Bus

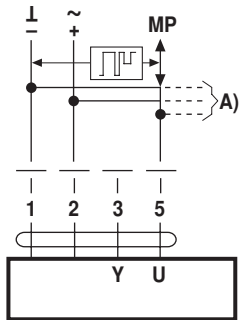

A) more actuators and sensors (max.8)

Network topology

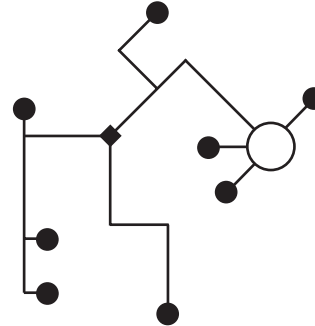

There are no restrictions for the network topology (star, ring, tree or mixed forms are permitted). Supply and communication in one and the same 3-wire cable

- no shielding or twisting necessary
- no terminating resistors required

Connection of active sensors

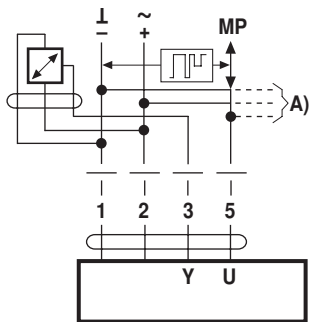

A) more actuators and sensors (max.8)

- Supply AC/DC 24 V
- Output signal DC 0...10 V (max. DC 0...32 V)
- Resolution 30 mV

Connection of external switching contact

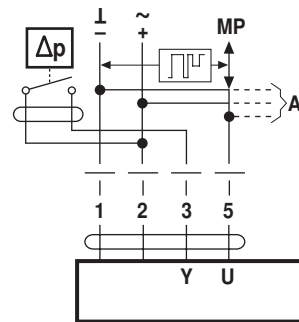

A) more actuators and sensors (max.8)

- Switching current 16 mA @ 24 V
- Start point of the operating range must be parameterised on the MP actuator as  $\geq 0.5$  V

Connection of passive sensors

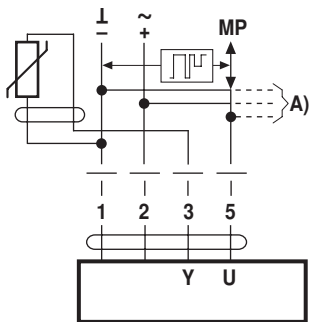

Ni1000	-28...+98 °C	850...1600 $\Omega^2$ )
PT1000	-35...+155 °C	850...1600 $\Omega^2$ )
NTC	-10...+160 °C <sup>1)</sup>	200 $\Omega$ ...60 k $\Omega^2$ )

A) more actuators and sensors (max.8)

1) Depending on the type  
2) Resolution 1 Ohm

Functions with basic values (conventional mode)

Override control with AC 24 V with relay contacts

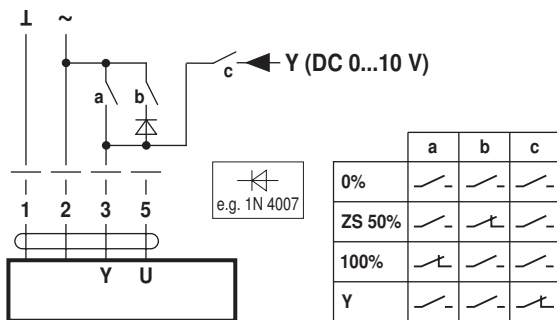

Override control with AC 24 V with rotary switch

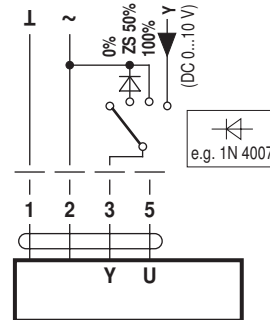

**Functions**

Remote control 0...100% with positioner SG.. Minimum limit with positioner SG..  
 positioner SG..

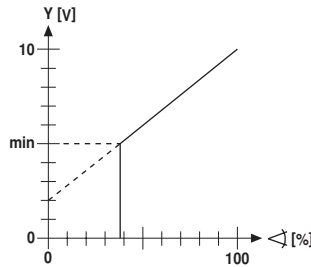
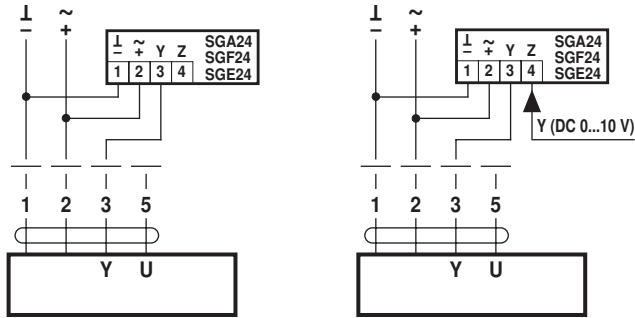

Follow-up control (position-dependent)

Position indication

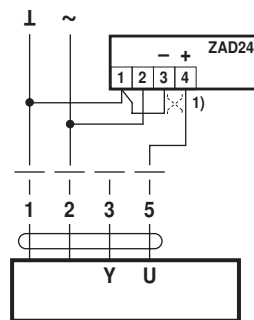
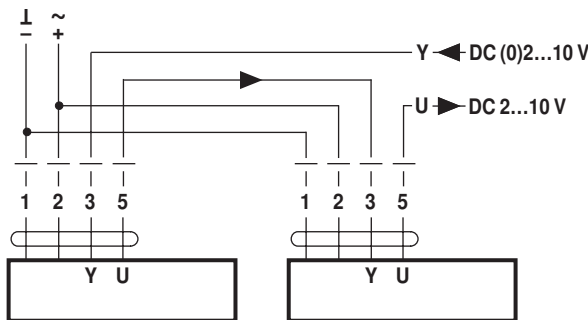

Control with 4...20 mA via external resistor

Functional check

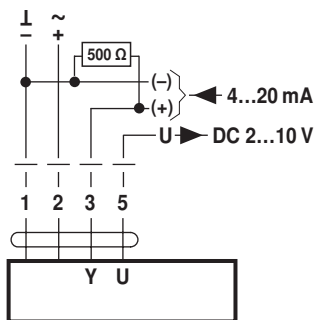

**Caution:**  
 The operating range must be set to DC 2...10 V.  
 The 500 Ω resistor converts the 4...20 mA current signal to a voltage signal DC 2...10 V

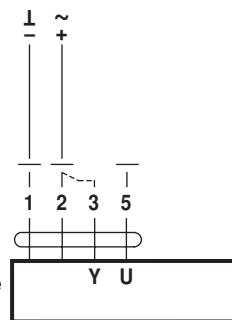

(1) Adapting the direction of rotation

**Procedure**

1. Connect 24V to connections 1 and 2
2. Disconnect connection 3:
  - with direction of rotation 0: Actuator rotates to the left
  - with direction of rotation 1: Actuator rotates to the right
3. Short-circuit connections 2 and 3:
  - Actuator runs in opposite direction

**Functions for actuators with specific parameters (Parametrisation with PC-Tool necessary)**

Override control and limiting with AC 24 V with relay contacts

Override control and limiting with AC 24 V with rotary switch

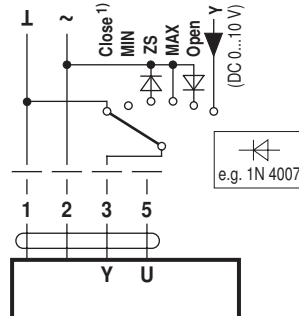
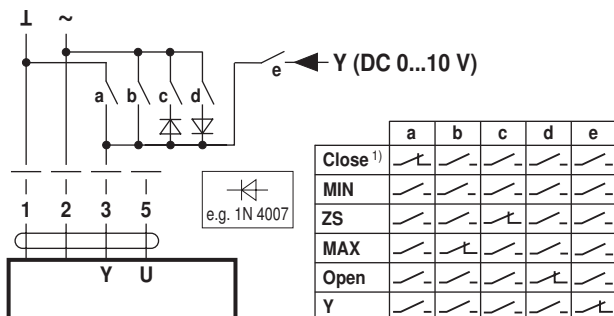

1) **Caution:** This function is only guaranteed if the start point of the operating range is defined as min. 0.5 V.

**Functions**

Control open-close

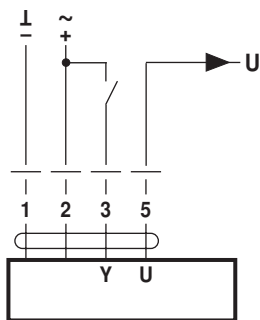

Control 3-point

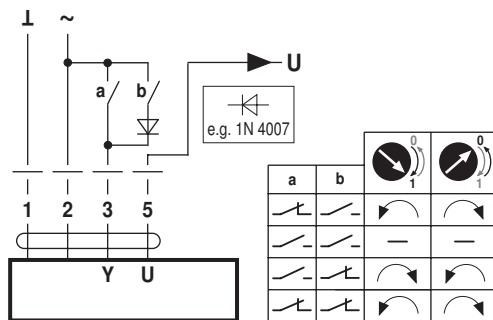

**Operating controls and indicators**

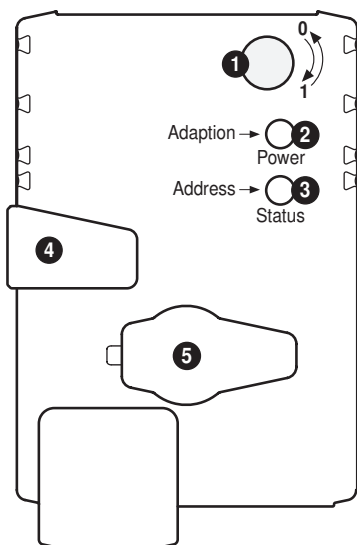

- 1 Direction of rotation switch**  
Switch over: Direction of rotation changes
  - 2 Push-button and LED display green**  
Off: No power supply or malfunction  
On: In operation  
Press button: Triggers angle of rotation adaptation, followed by standard mode
  - 3 Push-button and LED display yellow**  
Off: Standard mode  
Flickering: MP communication active  
On: Adaptation or synchronising process active  
Flashing: Request for addressing from MP master  
Press button: Confirmation of the addressing
  - 4 Gear disengagement button**  
Press button: Gear disengages, motor stops, manual override possible  
Release button: Gear engages, synchronisation starts, followed by standard mode
  - 5 Service plug**  
For connecting parameterisation and service tools
- Check power supply connection**  
2 Off and 3 On Possible wiring error in power supply

**Service**



**Notes**

- The actuator can be parameterised by PC-Tool and ZTH EU via the service socket.

ZTH EU connection

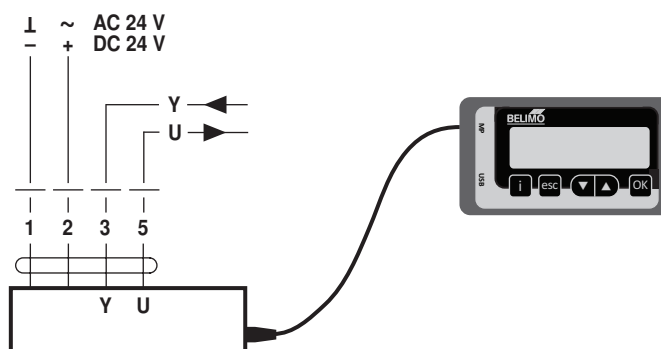

**Service**

PC-Tool connection

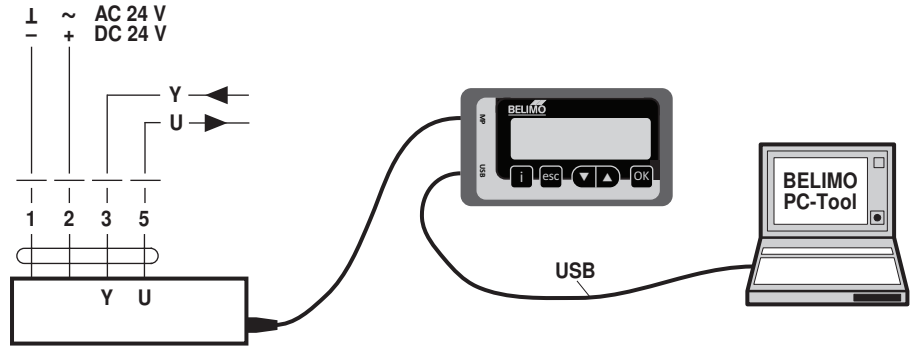

**Dimensions [mm]**

**Spindle length**

		Min. 40
		Min. 20

**Clamping range**

	8...26.7	≥8	≤26.7
	8...20*	≥8	≤20

\*Option: Spindle clamp mounted below  
(accessories K-NA needed)

**Dimensional drawings**

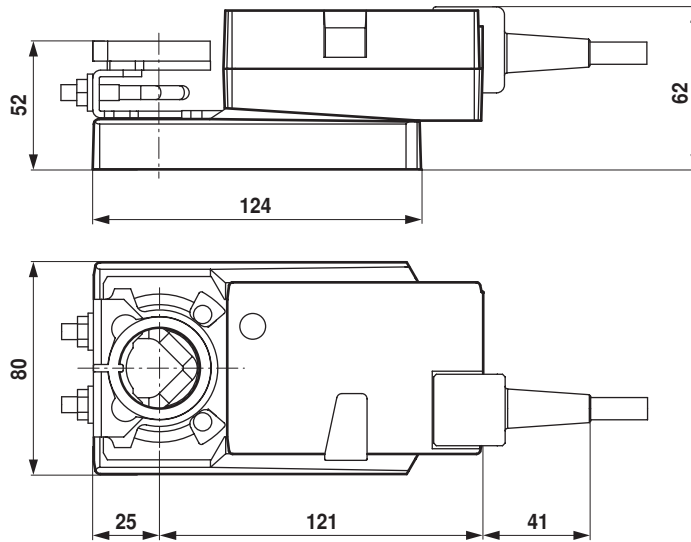

**Further documentation**

- Overview MP Cooperation Partners
- Tool connections